

# BONETTI®

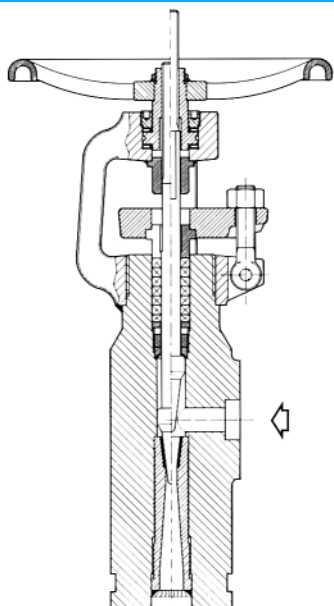

6093

**BONT®**  
**Forged Steel Valves**  
**Type BLB**  
 for  
**Continuous Blowdown**  
**ASME Class**  
**1700 - 2700 - 4500 lb**

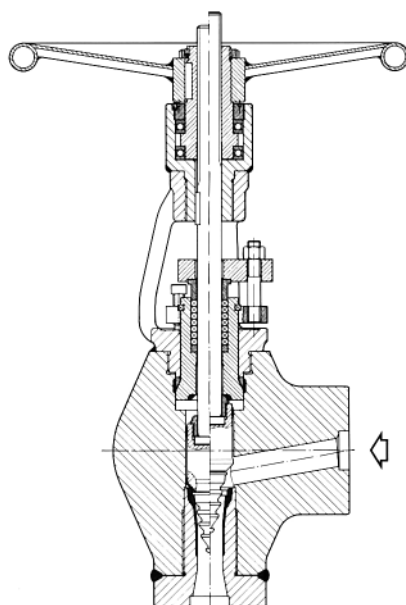

6094

**BONT®**  
**Forged Steel Valves**  
**Type BPR**  
 for Blowoff  
 with Zero Leakage  
 after Closing Operation  
**ASME Class**  
**1700 - 2700 - 4500 lb**



## CESARE BONETTI S.p.A.

I-20024 GARBAGNATE MILANESE (Italy)  
 Via Cesare Bonetti 17

<http://www.cesare-bonetti.it>

Bonetti Armaturen Vertriebs GmbH  
 D-65549 Limburg an der Lahn (Germany)  
 In den Fritzenstücker, 4

Bonetti Australia Pty Ltd  
 29/1140 Nepean Hwy (P.O. Box 2041)  
 MORNINGTON - Victoria - 3931 - Australia

Export sales: Telephone: +3902 99 072 444  
 Telefax: +3902 99 072 400  
 Vendite Italia: Telefono: +3902 99 072 333  
 Telefax: +3902 99 072 300

[export@cesare-bonetti.it](mailto:export@cesare-bonetti.it)

[italia@cesare-bonetti.it](mailto:italia@cesare-bonetti.it)

Sales Office Telephone: +49 06431 72041  
 Telefax: +49 06431 72066

[bonetti-germany@t.online.de](mailto:bonetti-germany@t.online.de)

Sales Office Telephone: +61 3 5977 1966  
 Telefax: +61 3 5977 1966

[dtsbont@hotmail.net.au](mailto:dtsbont@hotmail.net.au)

# BONT® Valves Type BLB, for Continuous Blowdown

Forged Steel - Bonnetless - Non-rotating Stem

ASME Class 1700 - 2700 - 4500 lb

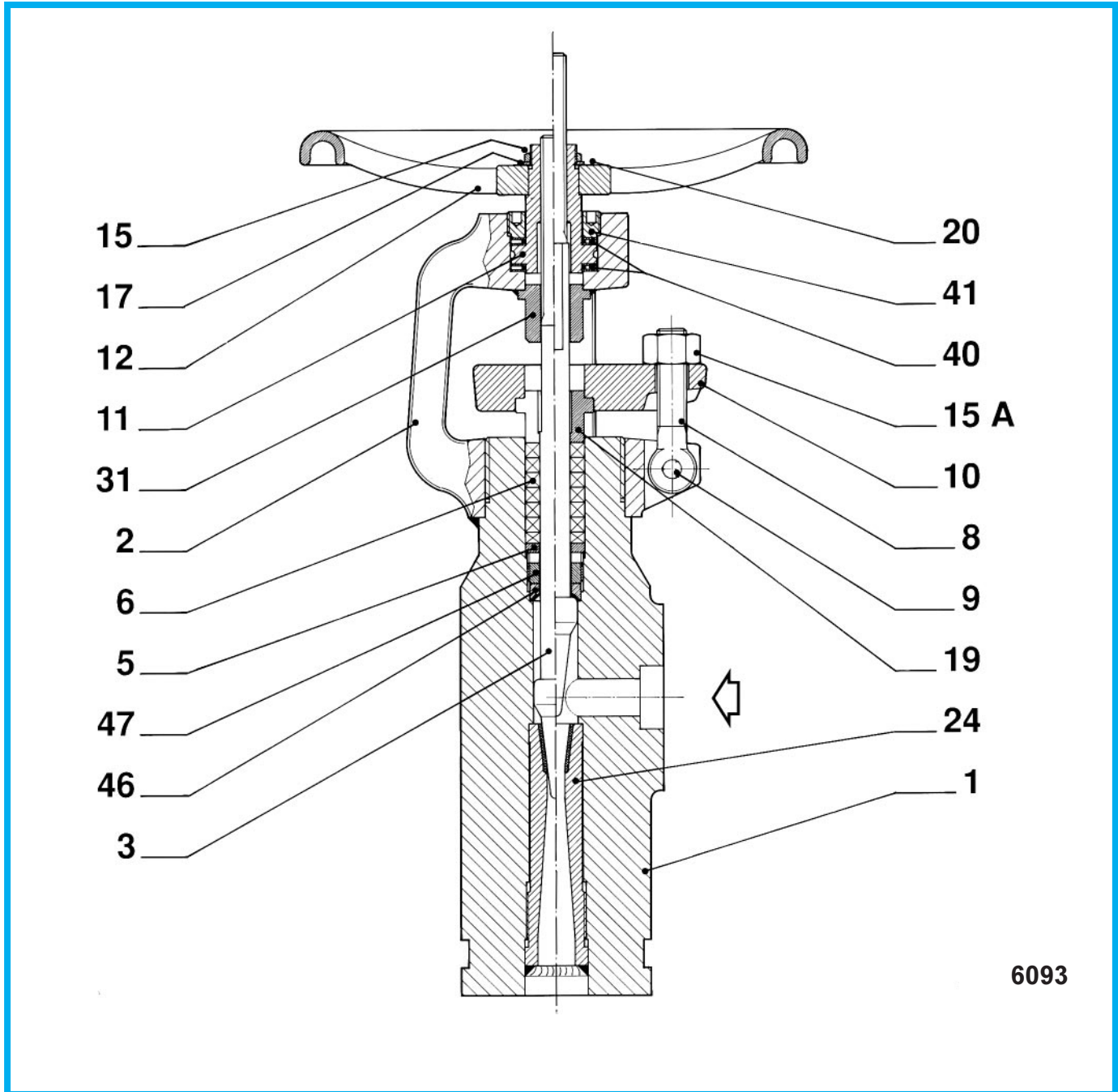

## Part Material for Material Schedule

Part No.	71	22	Part No.	71	22
1 Body	ASTM A105	ASTM A182 F22	24 Seat	ASTM A105 * + Stellite Gr. 6	ASTM A182 F22 * + Stellite Gr. 6
2 Yoke	ASTM A105	ASTM A105	31 Antirotation Ring	ASTM A182 F6 Alloy Steel	ASTM A182 F6 Alloy Steel
3 Disk - Stem	ASTM A479 410 c.3 * +Stellite Gr. 6	ASTM A479 410 c.3 * +Stellite Gr. 6	40 Thrust bearing	ASTM A182 F6	ASTM A182 F6
5 Bottom Ring	Stainless Steel)	Stainless Steel	41 Bushing Locking Ring	ASTM A182 F6	ASTM A182 F6
6 Packing	Graphite	Graphite	46 Backseat Ring	ASTM A479 316 + Stellite Gr. 6	ASTM A479 316 + Stellite Gr. 6
8 Swing Bolt	ASTM A193 B7	ASTM A193 B7	47 Backseat Locking Ring	ASTM A564 T.630	ASTM A564 T.630
9 Pin	Alloy Steel	Alloy Steel			
10 Packing Flange	ASTM A105	ASTM A105			
11 Yoke Bushing	ASTM B150 C62300	ASTM B150 C62300			
12 Handwheel	Nodular Cast Iron	Nodular Cast Iron			
15 Handwheelee Nut	Carbon Steel	Carbon Steel			
15A Bolt Nut	ASTM A194 2H	ASTM A194 2H			
17 Washer	Carbon Steel	Carbon Steel			
19 Split Gland	Stainless Steel	Stainless Steel			
20 Name Plate	Stainless Steel	Stainless Steel			

\* For use at condition lower than ASME 600 lb Class and temperature lower than 350 °C (662 °F) we can use ASTM A562 T.630



# BONT Valves Type BLB and PBR, for high $\Delta p$

ASME Class 1700 - 2700 - 4500 lb

## BONT® Valves Type BLB, for Continuous Blowdown

The continuous blowdown valves are needle valves designed for operation in open position. Their function is mainly to control a continuous flow of steam and/or water under high  $\Delta p$ .

For that reason the design and materials must be such as to minimise the effects of a fluid stream in condition of flashing or made of water containing sometime abrasive particles.

The outlet of our valves is purposely Venturi tube-shaped. The bonnetless design enables easy dismantling, inspection and maintenance. The stem is rising, non-rotating. A local stroke indicator shows the position of the disk.

The materials used for these valves are indicated on page 2 for the most requested Material Schedules, namely: Material Schedule 71, with carbon steel body; Material Schedule 22, with chromemolybdenum alloy steel body.

In spite of the above mentioned features, it can happen that these valves - after some operating time - are not able to ensure a tight seal, since even a slow-acting erosion deteriorates the working surfaces of the disk and seat. What above does not affect its function; the only consequence is a slight rise in the outflow rate, the disk being in the same position, remediable by closing a little the valve. The orifice can be selected in accordance with the Table Fig. 6095, where the section of the actual seat bore is indicated as a function of the upstream pressure as well as of the flow rate.

The downstream pressure does not affect the flow rate, being usually lower than the critical pressure.

The following data must be indicated for the selection of a BONT® valve, type BLB:

- fluid
- max flow rate
- upstream pressure P1
- downstream pressure P2
- temperature.

## BONT® Valves type PBR, for Blowoff

These valves are usually used when tight seal is needed after a blowoff operation. This utilization could be required by process necessity and/or economical reasons.

In the past the two functions were mostly performed by two different valves, fitted in series and operated in accordance with a definite sequence.

Our valve type PBR carries out both functions in sequence and namely: blowoff with valve suitably open and tight sealing with valve closed.

It is a multistage valve splitting the pressure drop along the whole disk that is along the different stages of the disk. The design of the disk, of the fluid path inside the valve as well the materials are suitable to operation with high  $\Delta p$ , therefore usually with critical flow.

The consequences of these critical flows of water/steam must not affect geometry and finish of the contact surfaces between main disk and main seat in order to ensure tight sealing with the passing of time. The pressure seal bonnet enables easy dismantling, inspection and maintenance. The stem is rising, non-rotating.

The materials used for these valves are shown on page 3 for the most requested Material Schedules, namely: Material Schedule 71 with carbon steel body; Material Schedule 22 with chromemolybdenum alloy steel body. The satisfactory results obtained on all installations confirm the suitability of our design to the most severe operating conditions.

The following data must be indicated for the selection of a BONT® valve, type PBR:

- fluid
- max flow rate
- upstream pressure P1
- downstream pressure P2
- temperature.

Remember what follows: the valve being fully open, the downstream pressure shall not be considered equal to the atmospheric pressure as well to the condenser vacuum; in fact there is a back pressure originated by the flowrate and the downstream pipe section.

## The operating range is very wide, in particular:

- Feedwater
  - P1 = 180 to 300 bar
  - P2 = 20 to 40 bar
  - T = 200 to 300 °C
  - Flow Rate up to 150 t/h
- Saturated and superheated steam
  - P1 = 35 to 180 bar
  - T = 350 to 550 °C
  - Ap >critical  $\Delta p$

## Nominal Sizes

up to 1" for Type BLB  
up to 3" for Type PBR

**Actuated valves.** The design of these valves with rising, non-rotating stem, as well their oversizing, enables easy assembly of any actuator type.

The actuator can be equipped with:

- torque limit switches, adjustable both at the time of delivery and on plant site;
- stroke limit switches;
- local position indicator;
- ON-OFF remote transmitters;
- ancillary switches for various warnings/operations;
- inductive or resistive position transmitter.

Fig. 6095 - Chart of Flow Rate for Continuous Blowdown

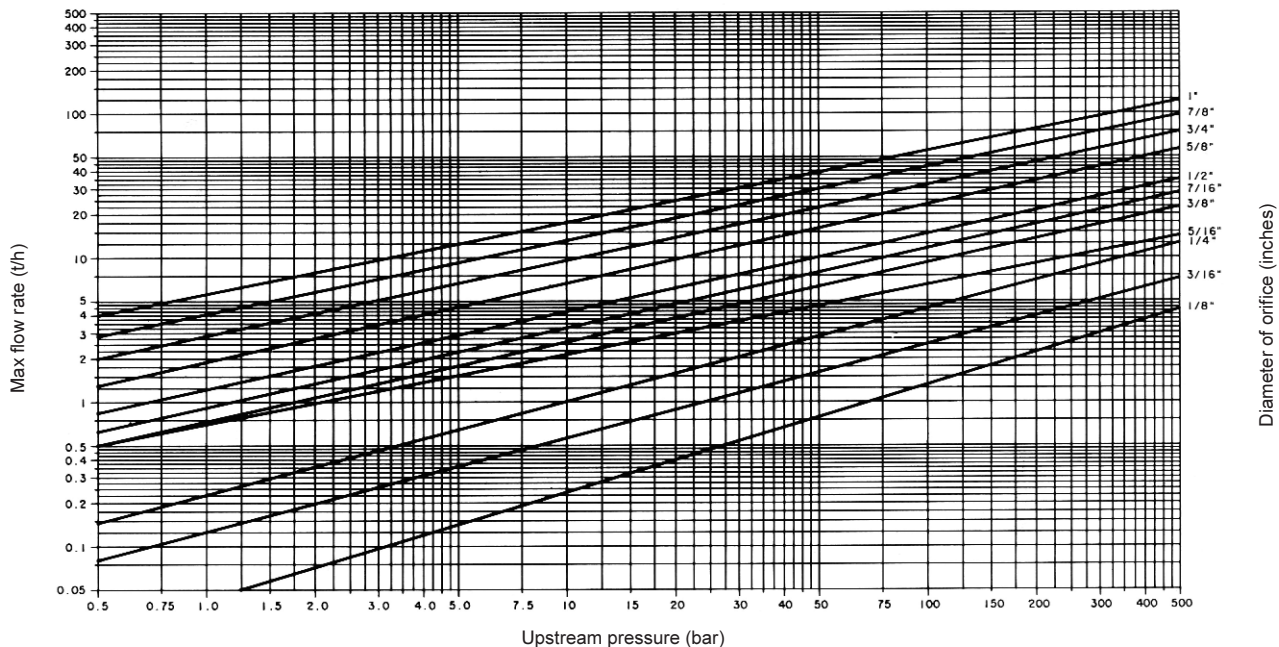

We reserve the right to carry out any necessary alterations, without notice.