

## Dosing systems for dishwashing machines

### TWINDOSE 20

A compact automated detergent and rinse aid dispenser, TWINDOSE 20 is suitable for use with all professional dishwashing machines, designed to reduce manual work.



- SIMPLE TO INSTALL**
- Simply run the rinse and detergent supply lines and connect to the dishwasher's solenoid valves.
  - Simple to personalize, according to the type of dishwasher, for optimized dosing.

- EASY TO USE**
- Simple dosing control via the pump's speed trimmer.
  - Universal voltage input from 24 to 230 VAC
  - Separate priming switches for each pump.

- SAFE AND RELIABLE**
- All controls are inside the casing to prevent unauthorized tampering.
  - IP65-level protection versus dust and water sprays.
  - Class 2 electrical connections: there is no need for a ground wire.

- MINIMUM MAINTENANCE**
- Thanks to Seko's long experience with peristaltic pumps, maintenance is very easy and requires only a few seconds.
  - No special tools are required, and there is no need to start the pumps.

## Installation kit



## Suggested accessories



"T" connector

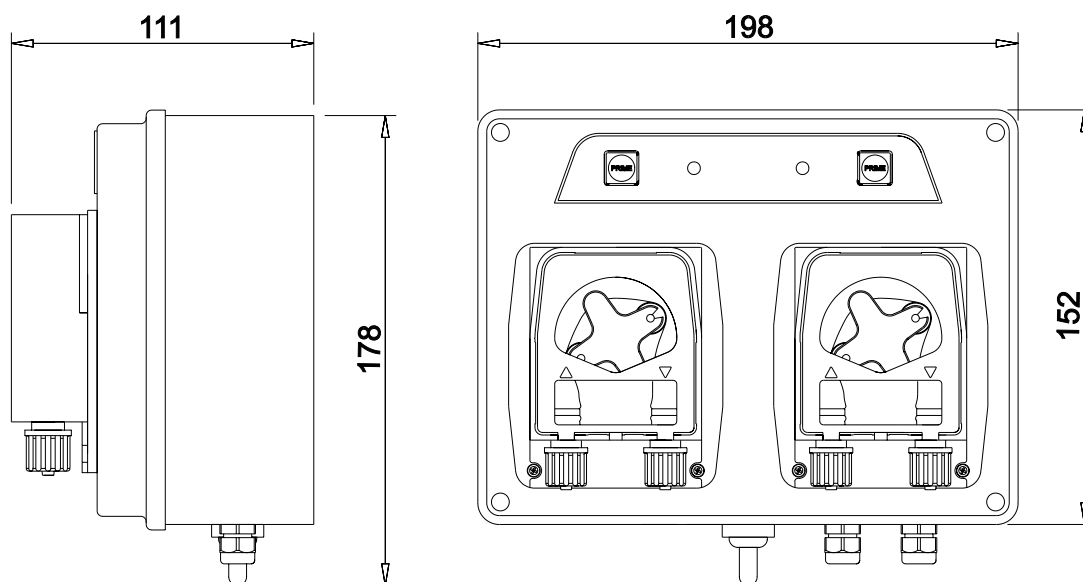

## Specification

Voltage first charge solenoid valve input	20÷265 Vac
Voltage rinse-aid solenoid valve input	20÷265 Vac
Current consumption	8 VA
End products alarm input	Lev.4 level probe
Plastic container according to class of protection	IP65
Electrical class	2
Weight	1,2 Kg

### DETERGENT PUMP

Flow-rate adjustment	up to 7 l/h
Peristaltic tube	Santoprene

### RINSE AID PUMP

Maximum pressure	3 bar
Flow-rate adjustment	from 0.18 to 1 l/h
Peristaltic tube	Sekobril